

MB770

VIA CN700

Mini ITX Motherboard

USER'S MANUAL

Version 1.0

Acknowledgments

Award is a registered trademark of Award Software International, Inc.

PS/2 is a trademark of International Business Machines Corporation.

Microsoft Windows is a registered trademark of Microsoft Corporation.

Winbond is a registered trademark of Winbond Electronics Corporation.

All other product names or trademarks are properties of their respective owners.

Table of Contents

Introduction	1
Product Description.....	1
Checklist.....	2
Specifications	3
Board Dimensions	4
Installations	5
Installing the Memory	6
Setting the Jumpers	7
Connectors on MB770	11
BIOS Setup.....	29
Drivers Installation	51
VIA CN700 4 in 1 Driver Installation.....	52
Realtek AC'97 Codec Audio Driver Installation	54
VIA VT8237 LAN Driver Installation.....	55
Realtek Gigabit LAN Driver Installation	55
VIA RAID Driver Installation.....	56
VIA CN700 VGA Driver Installation	58
Appendix	59
A. I/O Port Address Map.....	59
B. Interrupt Request Lines (IRQ)	60

This page is intentionally left blank.

Introduction

Product Description

The MB770 Mini ITX board incorporates the VIA CN700 chipset. Currently, the board is available in two models, namely:

1. MB770 - VIA Eden-V4 400MHz, CN700 chipset, Mini-ITX w/ 10/100 LAN, VGA, Mini PCI, SATA
2. MB770F - VIA Eden-V4 1GHz, CN700 chipset, Mini-ITX w/ 10/100 LAN, Gigabit LAN, VGA, Mini PCI, SATA, TV out

Optional for the MB770/MB770F is the ID393 daughter card that supports DVI interface.

Basically, the MB770 has the following features:

- VIA CN700 Chipset with VIA CPU
- Up to 1GHz speed and 1GB DDR2 memory
- Integrated VGA, support 18/24-bit LVDS LCD
- 10/100 LAN1 on board, optional Gigabit LAN for LAN2
- 6 x USB, 2 x SATA ports
- 4 COM ports, Watchdog timer
- PCI and Mini PCI slots on board, optional TV out

Remarks: The onboard PCI slot supports 2 masters.

Checklist

Your MB770 package should include the items listed below.

- The MB770 VIA Eden-V4 Mini-ITX motherboard
- This User's Manual
- 1 CD containing chipset drivers and flash memory utility
- Cable kit (IDE, Serial port, Serial ATA)
- Optional daughter cards: ID393: VIA VT1632A, single DVI
- Optional cables: USB cable (USB2K-4), Audio cable (AUDIO-1), SATA Power cable (PW34), Slim FDD cable (FF2)

Specifications

Product Name	MB770
Form Factor	Mini ITX
CPU Type	VIA C7 or Eden-V4 NanoBGA2 (21x21mm) package Eden-V4: 1.0~1.2GHz (heatsink only for fanless) C7: 1.5~2.0GHz (heatsink w/ fan)
CPU Voltage	1.004V ~ 1.148V
CPU FSB	400MHz/533MHz
Cache	128KB L2 (CPU integrated)
Green / APM	APM1.2
Chipset	VIA CN700/8237R+ chipset North bridge: CN700 567-pin HSBGA South bridge: VT8237R+ 539-pin PBGA
BIOS	Award BIOS supports ACPI function
Memory	One DDR2 DIMM socket, supports up to 1GB
VGA	VIA CN700 built-in 128-bit Unichrome Pro 3D/2D controller
DVI	ID393: VIA VT1632A for DVI with DVI edge connector (above the dual USB stack) <i>REMARKS: When ID393 is used, dual independeng display (DVI + LVDS extension mode) is not supported. Mirror mode is supported (DVI and LVDS with same display); DVI / LVDS single display is supported.</i>
LVDS	VIA VT1631L for 18 or 24 dual channel LVDS
LAN	LAN1: VIA 8237R+ built-in 10/100 + VIA VT6103 PHY LAN2: / RTL8110S-32 Gigabit LAN (option on MB770F)
USB	VIA VT8237R+ built-in USB 2.0, supports 6 ports
Serial ATA	VIA VT8237R+ built-in SATA controller, supports 2 ports w/ RAID 0, 1, (VT8237R+ supports SATA II)
IDE Interface	Two channels; supports Ultra DMA 33/66/100/133
Audio	VIA VT8237R+ built-in Audio controller + AC97 Codec ALC 655; 5.1 Channel (Line-out, Line-in & Mic.)
LPC I/O	Winbond W83697HF: COM1, COM2 (RS-232), IrDA, Floppy & hardware monitor (2 thermal inputs, 5 voltage monitor inputs, 1 chassis open detection & 2 fan headers). Parallel port not used
Secondary I/O	Fintek F81216D for COM3, 4 (RS-232)
RTC/CMOS	VIA VT8237R+ built-in RTC with on board Lithium Battery
KB/Mouse	Supports PS/2 Keyboard/Mouse
Expansion Slot	PCI slot x 1 (supports 2 bus masters) and Mini-PCI x 1
Edge Connectors	PS/2 KB & MS, RCA Jack + S-Video connector, DVI, VGA, COM1, RJ45, dual USB, optional 2nd RJ45 for MB770F, dual USB for USB3/4, Audio connectors (Speaker, Line In, Mic)
On Board Connector / Header	2 Serial ATA connectors, IDE1 40-pin box-header, IDE2 44-pin header, 2 LVDS DF13 20-pin header, COM2/3/4 30-pin header, Audio 12-pin header, USB5/6 8-pin header, slim type FDD header, IrDA 5-pin header, System function 20-pin header
Power Connector	ATX power connector
Watchdog Timer	Yes (256 segments: 0, 1, 2, ..., 255 sec/min)
Board Size	170mm x 170mm

Board Dimensions

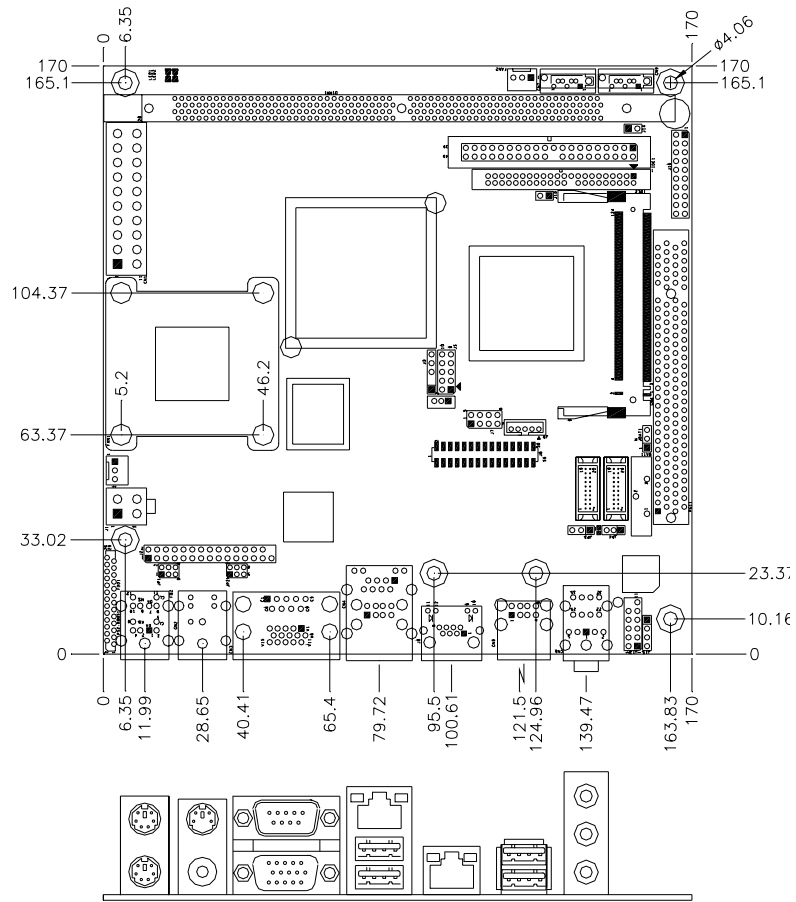

Installations

This section provides information on how to use the jumpers and connectors on the MB770 in order to set up a workable system. The topics covered are:

Installing the Memory	6
Setting the Jumpers	7
Connectors on MB770	11

Installing the Memory

The MB770 board supports one DDR2 memory socket for a maximum total memory of 1GB in DDR2 memory type.

Installing and Removing Memory Modules

To install the DDR2 modules, locate the memory slot on the board and perform the following steps:

1. Hold the DDR2 module so that the key of the DDR2 module align with those on the memory slot.
2. Gently push the DDR2 module in an upright position until the clips of the slot close to hold the DDR2 module in place when the DDR2 module touches the bottom of the slot.
3. To remove the DDR2 module, press the clips with both hands.

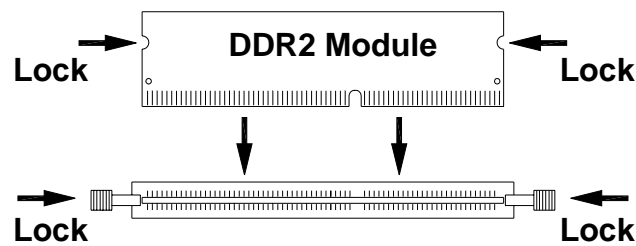

Setting the Jumpers

Jumpers are used on MB770 to select various settings and features according to your needs and applications. Contact your supplier if you have doubts about the best configuration for your needs. The following lists the connectors on MB770 and their respective functions.

Jumper Locations on MB770	8
JP1: COM3 RS232 +5V / +12V Power Setting	9
JP2: COM4 RS232 +5V / +12V Power Setting	9
JP3: LCD Panel Power Selection	9
JP4: LCD Panel Channel Selection	9
J10: Secondary IDE UDMA Selection.....	10
JBAT1: Clear CMOS Setting	10

JP1: COM3 RS232 +5V / +12V Power Setting

Pin #	Signal Name	JP1	Signal Name	Pin #
1	RI		+12V	2
3	RI (Default)		RI (Default)	4
5	RI		+5V	6

COM3 Settings: Pin 1-2 short = +12V, Pin 5-6 short = +5V, Pin 3-4 Standard COM Port

JP2: COM4 RS232 +5V / +12V Power Setting

Pin #	Signal Name	JP2	Signal Name	Pin #
1	RI		+12V	2
3	RI (Default)		RI (Default)	4
5	RI		+5V	6

COM4 Settings: Pin 1-2 short = +12V, Pin 6-5 short = +5V, Pin 3-4 Standard COM Port



JP3: LCD Panel Power Selection

JP3	LCD Panel Power
	3.3V
	5V



JP4: LCD Panel Channel Selection

JP4	Setting
	Dual
	Single

J10: Secondary IDE UDMA Selection

J10	UDMA Setting
 Short	GPI Selection
 Open	UDMA33 (Default)

JBAT1: Clear CMOS Setting

JBAT1	Setting
 1 2 3	Normal
 1 2 3	Clear CMOS

Connectors on MB770

The connectors on MB770 allows you to connect external devices such as keyboard, floppy disk drives, hard disk drives, printers, etc. The following table lists the connectors on MB770 and their respective functions.

Connector Locations on MB770	12
PS2-KBMS: PS/2 Keyboard and PS/2 Mouse Connectors	13
CN2: TV out RCA and S-Video Connector	13
CN3: COM1 and VGA Connector	13
CN4: 10/100 RJ-45 and USB1/2 Ports	14
CN5: USB3/4 Ports	14
J6: Gigabit LAN RJ-45	14
CN7, CN9: Serial ATA Connectors	14
CN8: Line Out, Line In, Mic Connector	14
FAN1: CPU Fan Power Connector	14
FAN2: System Fan Power Connector	14
IDE1, IDE2: Primary and Secondary IDE Connectors	15
FDD1: Floppy Drive Connector	16
J2: Serial Ports	16
J3: IrDA Connector	17
J4: Wake On LAN Connector	17
J5: Digital I/O	17
J7: USB5/6 Port Pin Header	17
J8: GDVP (DVI) Port Connector	18
J9: LCD Inverter Output	18
J11, J12: LVDS Connectors (1st channel, 2nd channel)	18
J13: External Audio Connector	19
J15: CD-in Connector	19
J16: System Function Connector	19
CN1: ATX Power Supply Connector	21
CN6: Mini PCI Connector	21
PCI1: PCI Slot (supports 2 Master)	21
ID393 - MB770 Daughter Card	22
J1: DVI Connector (DVI-D, for single DVI)	22
J2: GDVP (DVI) Port Connector	22

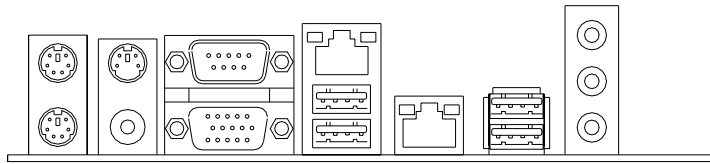

PS2-KBMS: PS/2 Keyboard and PS/2 Mouse Connectors

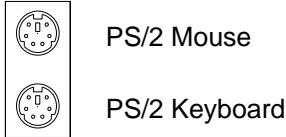

Signal Name	Keyboard	Mouse	Signal Name
Keyboard data	1	1	Mouse data
N.C.	2	2	N.C.
GND	3	3	GND
5V	4	4	5V
Keyboard clock	5	5	Mouse clock
N.C.	6	6	N.C.

CN2: TV out RCA and S-Video Connector

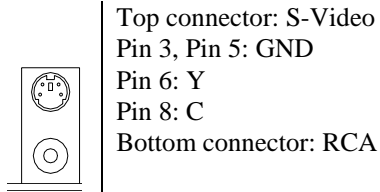

CN3: COM1 and VGA Connector

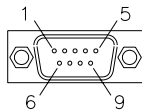

Signal Name	Pin #	Pin #	Signal Name
DCD	1	6	DSR
RXD	2	7	RTS
TXD	3	8	CTS
DTR	4	9	RI
GND	5	10	Not Used

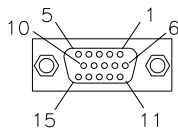

Signal Name	Pin #	Pin #	Signal Name
Red	1	2	Green
Blue	3	4	N.C.
GND	5	6	GND
GND	7	8	GND
N.C.	9	10	GND
N.C.	11	12	N.C.
HSYNC	13	14	VSYNC
NC	15		

CN4: 10/100 RJ-45 and USB1/2 Ports

CN5: USB3/4 Ports

J6: Gigabit LAN RJ-45

CN7, CN9: Serial ATA Connectors

CN8: Line Out, Line In, Mic Connector

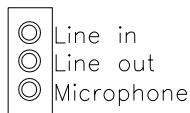

FAN1: CPU Fan Power Connector

FAN1 is a 3-pin header for the CPU fan. The fan must be a 12V fan.



Pin #	Signal Name
1	Ground
2	+12V
3	Rotation detection

FAN2: System Fan Power Connector

FAN2 is a 3-pin header for system fans. The fan must be a 12V fan.



Pin #	Signal Name
1	Ground
2	+12V
3	Rotation detection

IDE1, IDE2: Primary and Secondary IDE Connectors

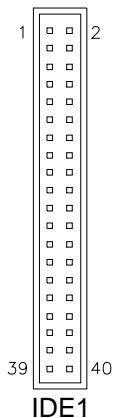

Signal Name	Pin #	Pin #	Signal Name
Reset IDE	1	2	Ground
Host data 7	3	4	Host data 8
Host data 6	5	6	Host data 9
Host data 5	7	8	Host data 10
Host data 4	9	10	Host data 11
Host data 3	11	12	Host data 12
Host data 2	13	14	Host data 13
Host data 1	15	16	Host data 14
Host data 0	17	18	Host data 15
Ground	19	20	Protect pin
DRQ0	21	22	Ground
Host IOW	23	24	Ground
Host IOR	25	26	Ground
IOCHRDY	27	28	Host ALE
DACK0	29	30	Ground
IRQ14	31	32	No connect
Address 1	33	34	No connect
Address 0	35	36	Address 2
Chip select 0	37	38	Chip select 1
Activity	39	40	Ground

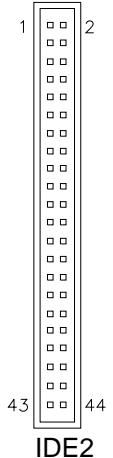

Signal Name	Pin #	Pin #	Signal Name
Reset IDE	1	2	Ground
Host data 7	3	4	Host data 8
Host data 6	5	6	Host data 9
Host data 5	7	8	Host data 10
Host data 4	9	10	Host data 11
Host data 3	11	12	Host data 12
Host data 2	13	14	Host data 13
Host data 1	15	16	Host data 14
Host data 0	17	18	Host data 15
Ground	19	20	Key
DRQ0	21	22	Ground
Host IOW	23	24	Ground
Host IOR	25	26	Ground
IOCHRDY	27	28	Host ALE
DACK0	29	30	Ground
IRQ14	31	32	No connect
Address 1	33	34	No connect
Address 0	35	36	Address 2
Chip select 0	37	38	Chip select 1
Activity	39	40	Ground
Vcc	41	42	Vcc
Ground	43	44	N.C.

FDD1: Floppy Drive Connector

FDD1 is a slim 26-pin connector and will support up to 2.88MB FDD.

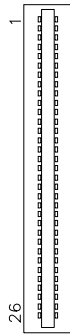

Signal Name	Pin #	Pin #	Signal Name
VCC	1	2	INDEX
VCC	3	4	DRV_SEL
VCC	5	6	DSK_CH
NC	7	8	NC
NC	9	10	MOTOR
DINST	11	12	DIR
NC	13	14	STEP
GND	15	16	WDATA
GND	17	18	WGATE
GND	19	20	TRACK
NC	21	22	WPROT
GND	23	24	RDATA
GND	25	26	SIDE

J2: Serial Ports

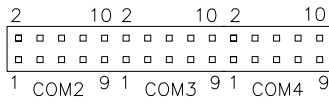

Pin #	Signal Name (RS-232)
1	DCD, Data carrier detect
3	RXD, Receive data
5	TXD, Transmit data
7	DTR, Data terminal ready
9	Ground
2	DSR, Data set ready
4	RTS, Request to send
6	CTS, Clear to send
8	RI, Ring indicator
10	No Connect.

J3: IrDA Connector

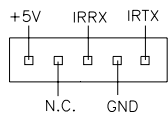

Pin #	Signal Name
1	+5V
2	No connect
3	IR RX
4	Ground
5	IR TX

J4: Wake On LAN Connector

J4 is a 3-pin header for the Wake On LAN function. Wake On LAN will function properly only with an ATX power supply with 5VSB that has 200mA.



Pin #	Signal Name
1	+5VSB
2	Ground
3	-PME

J5: Digital I/O

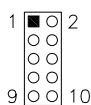

Signal Name	Pin	Pin	Signal Name
GND	1	2	VCC
OUT3	3	4	OUT1
OUT2	5	6	OUT0
IN3	7	8	IN1
IN2	9	10	IN0

J7: USB5/6 Port Pin Header



Signal Name	Pin	Pin	Signal Name
Vcc	1	5	Ground
D-	2	6	D+
D+	3	7	D-
Ground	4	8	Vcc

J8: GDVP (DVI) Port Connector

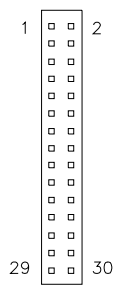

Signal Name	Pin #	Pin #	Signal Name
+5V	1	2	+5V
+5V	3	4	+5V
+3.3V	5	6	+3.3V
+1.5V	7	8	+1.5V
SMB_DA	9	10	SMB_CK
HS	11	12	VS
D0	13	14	DE
D2	15	16	D1
D4	17	18	D3
GND	19	20	D5
CLK	21	22	GND
CLK_N	23	24	GND
D7	25	26	D5
D9	27	28	D8
D11	29	30	D10

J9: LCD Inverter Output

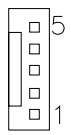

Pin #	Signal Name
1	+12V
2	Ground
3	BLT_ON
4	NC
5	Vcc

J11, J12: LVDS Connectors (1st channel, 2nd channel)

The LVDS connectors on board consist of the first channel (J11) and second channel (J12) and supports single or dual channel 18-bit or 24-bit.

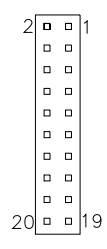

Signal Name	Pin #	Pin #	Signal Name
TX0-	2	1	TX0+
Ground	4	3	Ground
TX1-	6	5	TX1+
5V/3.3V	8	7	Ground
TX3-	10	9	TX3+
TX2-	12	11	TX2+
Ground	14	13	Ground
TXC-	16	15	TXC+
5V/3.3V	18	17	ENABKL
+12V	20	19	+12V

J13: External Audio Connector

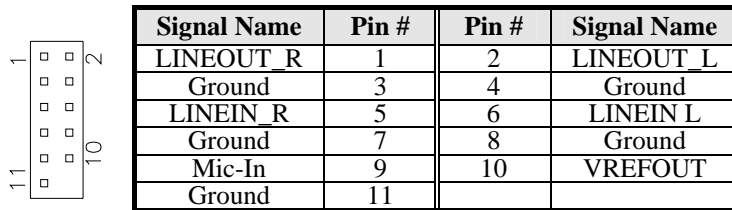

J15: CD-in Connector

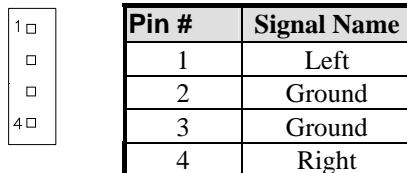

J16: System Function Connector

J16 provides connectors for system indicators that provide light indication of the computer activities and switches to change the computer status. J16 is a 20-pin header that provides interfaces for the following functions.

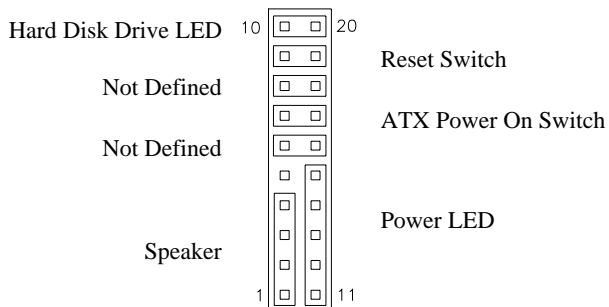

Speaker: Pins 1 - 4

This connector provides an interface to a speaker for audio tone generation. An 8-ohm speaker is recommended.

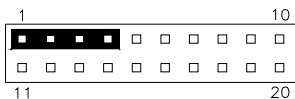

Pin #	Signal Name
1	Speaker out
2	No connect
3	Ground
4	+5V

Power LED: Pins 11 - 15

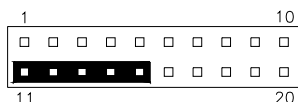

Pin #	Signal Name
11	Power LED
12	No connect
13	Ground
14	No connect
15	Ground

ATX Power ON Switch: Pins 7 and 17

This 2-pin connector is an “ATX Power Supply On/Off Switch” on the system that connects to the power switch on the case. When pressed, the power switch will force the system to power on. When pressed again, it will force the system to power off.

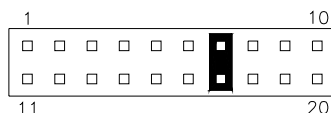

Reset Switch: Pins 9 and 19

The reset switch allows the user to reset the system without turning the main power switch off and then on again. Orientation is not required when making a connection to this header.

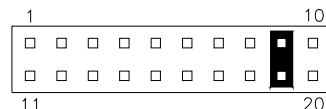

Hard Disk Drive LED Connector: Pins 10 and 20

This connector connects to the hard drive activity LED on control panel. This LED will flash when the HDD is being accessed.

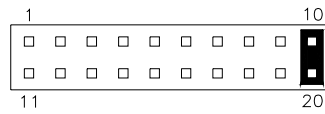

Pin #	Signal Name
10	HDD Active
20	5V

CN1: ATX Power Supply Connector

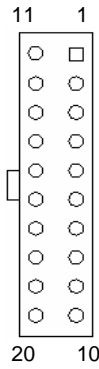

Signal Name	Pin #	Pin #	Signal Name
3.3V	11	1	3.3V
-12V	12	2	3.3V
Ground	13	3	Ground
PS-ON	14	4	+5V
Ground	15	5	Ground
Ground	16	6	+5V
Ground	17	7	Ground
-5V	18	8	Power good
+5V	19	9	5VSB
+5V	20	10	+12V

CN6: Mini PCI Connector

PCI1: PCI Slot (supports 2 Master)

ID393 - MB770 Daughter Card

REMARKS: When ID393 is used, dual independent display (DVI + LVDS extension mode) is not supported. Mirror mode is supported (DVI and LVDS with same display); DVI / LVDS single display is supported.

J1: DVI Connector (DVI-D, for single DVI)

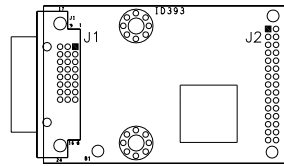

J2: GDVP (DVI) Port Connector

Signal Name	Pin #	Pin #	Signal Name
+5V	1	2	+5V
+5V	3	4	+5V
+3.3V	5	6	+3.3V
+1.5V	7	8	+1.5V
SMB_DA	9	10	SMB_CK
HS	11	12	VS
D0	13	14	DE
D2	15	16	D1
D4	17	18	D3
GND	19	20	D5
CLK	21	22	GND
CLK_N	23	24	GND
D7	25	26	D5
D9	27	28	D8
D11	29	30	D10

Watchdog Timer Configuration

The WDT is used to generate a variety of output signals after a user programmable count. The WDT is suitable for use in the prevention of system lock-up, such as when software becomes trapped in a deadlock. Under these sort of circumstances, the timer will count to zero and the selected outputs will be driven. Under normal circumstance, the user will restart the WDT at regular intervals before the timer counts to zero.

SAMPLE CODE:

This code and information is provided "as is" without warranty of any kind, either expressed or implied, including but not limited to the implied warranties of merchantability and/or fitness for a particular purpose.

```

Filename : Main.cpp
=====
//
// THIS CODE AND INFORMATION IS PROVIDED "AS IS" WITHOUT WARRANTY OF ANY
// KIND, EITHER EXPRESSED OR IMPLIED, INCLUDING BUT NOT LIMITED TO THE
// IMPLIED WARRANTIES OF MERCHANTABILITY AND/OR FITNESS FOR A PARTICULAR
// PURPOSE.
//
=====
#include <stdio.h>
#include <stdlib.h>
#include "W697HF.H"
=====
int main (int argc, char *argv[]);
void copyright(void);
void EnableWDT(int);
void DisableWDT(void);
=====
int main (int argc, char *argv[])
{
    unsigned char bBuf;
    unsigned char bTime;
    char **endptr;

    copyright();

    if (argc != 2)
    {
        printf(" Parameter incorrect!!\n");
        return 1;
    }

    if (Init_W697HF() == 0)
    {
        printf(" Winbond 83697HF is not detected, program abort.\n");
        return 1;
    }

    bTime = strtol (argv[1], endptr, 10);
    printf("System will reset after %d seconds\n", bTime);

    EnableWDT(bTime);

    return 0;
}
=====
void copyright(void)
{
    printf("\n===== Winbond 697HF Watch Timer Tester (AUTO DETECT) =====\n\
        " Usage : W697WD reset_time\n\
        " Ex : W697WD 3 => reset system after 3 second\n\
        " W697WD 0 => disable watch dog timer\n");
}
=====
void EnableWDT(int interval)

```

```

{
    unsigned char bBuf;

    bBuf = Get_W697HF_Reg(0x29);
    bBuf &= (~0x60);
    bBuf |= 0x20;
    Set_W697HF_Reg(0x29, bBuf);                //enable WDTO

    Set_W697HF_LD(0x08);                      //switch to logic device 8

    bBuf = Get_W697HF_Reg(0xF3);
    bBuf &= (~0x04);
    Set_W697HF_Reg( 0xF3, bBuf);             //count mode is second

    Set_W697HF_Reg( 0xF4, interval);        //set timer
    Set_W697HF_Reg( 0x30, 0x01);           //enable timer
}
//=====
void DisableWDT(void)
{
    Set_W697HF_LD(0x08);                    //switch to logic device 8
    Set_W697HF_Reg(0x30, 0x00);            //watchdog disabled
    Set_W697HF_Reg(0xF4, 0x00);           //clear watchdog timer
}
//=====

Filename : W697hf.cpp
//=====
//
// THIS CODE AND INFORMATION IS PROVIDED "AS IS" WITHOUT WARRANTY OF ANY
// KIND, EITHER EXPRESSED OR IMPLIED, INCLUDING BUT NOT LIMITED TO THE
// IMPLIED WARRANTIES OF MERCHANTABILITY AND/OR FITNESS FOR A PARTICULAR
// PURPOSE.
//
//=====
#include "W697HF.H"
#include <dos.h>
//=====
unsigned int W697HF_BASE;
void Unlock_W697HF (void);
void Lock_W697HF (void);
//=====
unsigned int Init_W697HF(void)
{
    unsigned int result;
    unsigned char ucDid;

    W697HF_BASE = 0x2E;
    result = W697HF_BASE;

    ucDid = Get_W697HF_Reg(0x20);
    if ( ucDid == 0x60)
    {
        goto Init_Finish;
    }

    W697HF_BASE = 0x4E;
    result = W697HF_BASE;

    ucDid = Get_W697HF_Reg(0x20);
    if ( ucDid == 0x60)
    {
        goto Init_Finish;
    }

    W697HF_BASE = 0x00;
    result = W697HF_BASE;

Init_Finish:
    return (result);
}
//=====
void Unlock_W697HF (void)
{
    outportb(W697HF_INDEX_PORT, W697HF_UNLOCK);
    outportb(W697HF_INDEX_PORT, W697HF_UNLOCK);
}

```

```

}
//=====
void Lock_W697HF(void)
{
    outportb(W697HF_INDEX_PORT, W697HF_LOCK);
}
//=====
void Set_W697HF_LD(unsigned char LD)
{
    Unlock_W697HF();
    outportb(W697HF_INDEX_PORT, W697HF_REG_LD);
    outportb(W697HF_DATA_PORT, LD);
    Lock_W697HF();
}
//=====
void Set_W697HF_Reg(unsigned char REG, unsigned char DATA)
{
    Unlock_W697HF();
    outportb(W697HF_INDEX_PORT, REG);
    outportb(W697HF_DATA_PORT, DATA);
    Lock_W697HF();
}
//=====
unsigned char Get_W697HF_Reg(unsigned char REG)
{
    unsigned char Result;
    Unlock_W697HF();
    outportb(W697HF_INDEX_PORT, REG);
    Result = inportb(W697HF_DATA_PORT);
    Lock_W697HF();
    return Result;
}
//=====

Filename : W697hf.h
//=====
//
// THIS CODE AND INFORMATION IS PROVIDED "AS IS" WITHOUT WARRANTY OF ANY
// KIND, EITHER EXPRESSED OR IMPLIED, INCLUDING BUT NOT LIMITED TO THE
// IMPLIED WARRANTIES OF MERCHANTABILITY AND/OR FITNESS FOR A PARTICULAR
// PURPOSE.
//
//=====
#ifndef __W697HF_H
#define __W697HF_H                1
//=====
#define W697HF_INDEX_PORT        (W697HF_BASE)
#define W697HF_DATA_PORT        (W697HF_BASE+1)
//=====
#define W697HF_REG_LD            0x07
//=====
#define W697HF_UNLOCK            0x87
#define W697HF_LOCK              0xAA
//=====
unsigned int Init_W697HF(void);
void Set_W697HF_LD(unsigned char);
void Set_W697HF_Reg(unsigned char, unsigned char);
unsigned char Get_W697HF_Reg(unsigned char);
//=====
#endif __W697HF_H

```

Digital I/O Sample Code

Filename : Main.cpp

```
//-----
//
// THIS CODE AND INFORMATION IS PROVIDED "AS IS" WITHOUT WARRANTY OF ANY
// KIND, EITHER EXPRESSED OR IMPLIED, INCLUDING BUT NOT LIMITED TO THE
// IMPLIED WARRANTIES OF MERCHANTABILITY AND/OR FITNESS FOR A PARTICULAR
// PURPOSE.
//
//-----
#include <dos.h>
#include <conio.h>
#include <stdio.h>
#include <stdlib.h>
#include "W697HF.H"
//-----
void ClrKbBuf(void);
int main (int argc, char *argv[]);
void SetDioInupt(unsigned char);
unsigned char GetDioOutput(void);
//-----
int main (int argc, char *argv[])
{
    if (Init_W697HF() == 0)
    {
        printf("Can not detect Winbond 83697HF, program abort.\n");
        return(1);
    }

    printf("Current DIO input is 0x%X\n", GetDioOutput());

    printf("Set DIO output to high\n");
    SetDioInupt(0x0F);

    printf("Set DIO output to low\n");
    SetDioInupt(0x00);

    return 0;
}
//-----
void SetDioInupt(unsigned char data)
{
    Set_W697HF_LD( 0x07); //switch to logic device 7
    Set_W697HF_Reg(0xF1, ((data & 0x0F) << 4));
}
//-----
unsigned char GetDioOutput(void)
{
    unsigned char result;

    Set_W697HF_LD( 0x07); //switch to logic device 7
    result = Get_W697HF_Reg(0xF1, (data & 0x0F));
    return (result);
}
//-----
void ClrKbBuf(void)
{
    while(kbhit())
    {
        getch();
    }
}
//-----
```

```

Filename : W697hf.cpp
//=====
//
// THIS CODE AND INFORMATION IS PROVIDED "AS IS" WITHOUT WARRANTY OF ANY
// KIND, EITHER EXPRESSED OR IMPLIED, INCLUDING BUT NOT LIMITED TO THE
// IMPLIED WARRANTIES OF MERCHANTABILITY AND/OR FITNESS FOR A PARTICULAR
// PURPOSE.
//
//=====
#include "W697HF.H"
#include <dos.h>
//=====
unsigned int W697HF_BASE;
void Unlock_W697HF (void);
void Lock_W697HF (void);
//=====
unsigned int Init_W697HF(void)
{
    unsigned int result;

    W697HF_BASE = 0x2E;
    result = W697HF_BASE;
    if (Get_W697HF_Reg(0x20) == 0x60)
    {
        goto Init_Finish;
    }

    W697HF_BASE = 0x4E;
    result = W697HF_BASE;
    if (Get_W697HF_Reg(0x20) == 0x60)
    {
        goto Init_Finish;
    }

    W697HF_BASE = 0x00;
    result = W697HF_BASE;

Init_Finish:
    return (result);
}
//=====
void Unlock_W697HF (void)
{
    outportb(W697HF_INDEX_PORT, W697HF_UNLOCK);
    outportb(W697HF_INDEX_PORT, W697HF_UNLOCK);
}
//=====
void Lock_W697HF (void)
{
    outportb(W697HF_INDEX_PORT, W697HF_LOCK);
}
//=====
void Set_W697HF_LD( unsigned char LD)
{
    Unlock_W697HF();
    outportb(W697HF_INDEX_PORT, W697HF_REG_LD);
    outportb(W697HF_DATA_PORT, LD);
    Lock_W697HF();
}
//=====
void Set_W697HF_Reg( unsigned char REG, unsigned char DATA)
{
    Unlock_W697HF();
    outportb(W697HF_INDEX_PORT, REG);
    outportb(W697HF_DATA_PORT, DATA);
    Lock_W697HF();
}
//=====
unsigned char Get_W697HF_Reg(unsigned char REG)

```

```

{
    unsigned char Result;
    Unlock_W697HF();
    outportb(W697HF_INDEX_PORT, REG);
    Result = inportb(W697HF_DATA_PORT);
    Lock_W697HF();
    return Result;
}
//=====
Filename : W697hf.h
//=====
//
// THIS CODE AND INFORMATION IS PROVIDED "AS IS" WITHOUT WARRANTY OF ANY
// KIND, EITHER EXPRESSED OR IMPLIED, INCLUDING BUT NOT LIMITED TO THE
// IMPLIED WARRANTIES OF MERCHANTABILITY AND/OR FITNESS FOR A PARTICULAR
// PURPOSE.
//
//=====
#ifndef __W697HF_H
#define __W697HF_H                1
//=====
#define W697HF_INDEX_PORT        (W697HF_BASE)
#define W697HF_DATA_PORT        (W697HF_BASE+1)
//=====
#define W697HF_REG_LD            0x07
//=====
#define W697HF_UNLOCK            0x87
#define W697HF_LOCK              0xAA
//=====
unsigned int Init_W697HF(void);
void Set_W697HF_LD( unsigned char);
void Set_W697HF_Reg( unsigned char, unsigned char);
unsigned char Get_W697HF_Reg( unsigned char);
//=====
#endif //__W697HF_H

```

BIOS Setup

This chapter describes the different settings available in the Award BIOS that comes with the motherboard. The topics covered in this chapter are as follows:

BIOS Introduction	30
BIOS Setup	30
Standard CMOS Setup	32
Advanced BIOS Features	35
Advanced Chipset Features	38
Integrated Peripherals	42
Power Management Setup	44
PNP/PCI Configurations	47
PC Health Status	48
Frequency/Voltage Control	49
Load Fail-Safe Defaults	50
Load Optimized Defaults	50
Set Supervisor/User Password	50
Save & Exit Setup	50
Exit Without Saving	50

BIOS Introduction

The Award BIOS (Basic Input/Output System) installed in your computer system's ROM supports VIA processors. The BIOS provides critical low-level support for a standard device such as disk drives, serial ports and parallel ports. It also adds virus and password protection as well as special support for detailed fine-tuning of the chipset controlling the entire system.

BIOS Setup

The Award BIOS provides a Setup utility program for specifying the system configurations and settings. The BIOS ROM of the system stores the Setup utility. When you turn on the computer, the Award BIOS is immediately activated. Pressing the key immediately allows you to enter the Setup utility. If you are a little bit late pressing the key, POST (Power On Self Test) will continue with its test routines, thus preventing you from invoking the Setup. If you still wish to enter Setup, restart the system by pressing the "Reset" button or simultaneously pressing the <Ctrl>, <Alt> and <Delete> keys. You can also restart by turning the system Off and back On again. The following message will appear on the screen:

Press to Enter Setup

In general, you press the arrow keys to highlight items, <Enter> to select, the <PgUp> and <PgDn> keys to change entries, <F1> for help and <Esc> to quit.

When you enter the Setup utility, the Main Menu screen will appear on the screen. The Main Menu allows you to select from various setup functions and exit choices.

Phoenix - Award Workstation BIOS CMOS Setup Utility

Standard CMOS Features	Frequency/Voltage Control
Advanced BIOS Features	Load Fail-Safe Defaults
Advanced Chipset Features	Load Optimized Defaults
Integrated Peripherals	Set Supervisor Password
Power Management Setup	Set User Password
PnP/PCI Configurations	Save & Exit Setup
PC Health Status	Exit Without Saving
ESC : Quit	↑ ↓ → ← : Select Item
F10 : Save & Exit Setup	
Time, Date, Hard Disk Type...	

The section below the setup items of the Main Menu displays the control keys for this menu. At the bottom of the Main Menu just below the control keys section, there is another section, which displays information on the currently highlighted item in the list.

Note: *If the system cannot boot after making and saving system changes with Setup, the Award BIOS supports an override to the CMOS settings that resets your system to its default.*

Warning: *It is strongly recommended that you avoid making any changes to the chipset defaults. These defaults have been carefully chosen by both Award and your system manufacturer to provide the absolute maximum performance and reliability. Changing the defaults could cause the system to become unstable and crash in some cases.*

Standard CMOS Setup

“Standard CMOS Setup” choice allows you to record some basic hardware configurations in your computer system and set the system clock and error handling. If the motherboard is already installed in a working system, you will not need to select this option. You will need to run the Standard CMOS option, however, if you change your system hardware configurations, the onboard battery fails, or the configuration stored in the CMOS memory was lost or damaged.

Phoenix - Award WorkstationBIOS CMOS Setup Utility
Standard CMOS Features

Date (mm:dd:yy)	Wed, Feb 18 2004	Item Help
Time (hh:mm:ss)	00 : 00 : 00	Menu Level
IDE Channel 0 Master	None	Change the day, month, Year and century
IDE Channel 0 Slave	None	
IDE Channel 1 Master	None	
IDE Channel 1 Slave	None	
IDE Channel 2 Master	None	
IDE Channel 3 Master	None	
Drive A	1.44M, 3.5 in.	
Drive B	None	
Video	EGA/VGA	
Halt On	All, but keyboard	
Base Memory	640K	
Extended Memory	129024K	
Total Memory	130048K	

At the bottom of the menu are the control keys for use on this menu. If you need any help in each item field, you can press the <F1> key. It will display the relevant information to help you. The memory display at the lower right-hand side of the menu is read-only. It will adjust automatically according to the memory changed.

Date

The date format is:

Day : Sun to Sat
Month : 1 to 12
Date : 1 to 31
Year : 1994 to 2079

To set the date, highlight the “Date” field and use the PageUp/ PageDown or +/- keys to set the current time.

Time

The time format is: **Hour : 00 to 23**
Minute : 00 to 59
Second : 00 to 59

To set the time, highlight the "Time" field and use the <PgUp>/<PgDn> or +/- keys to set the current time.

IDE Channel 0/1 HDDs

The onboard PCI IDE connectors provide Primary and Secondary channels for connecting up to four IDE hard disks or other IDE devices. Each channel can support up to two hard disks; the first is the "Master" and the second is the "Slave".

Press <Enter> to configure the hard disk. The selections include Auto, Manual, and None. Select 'Manual' to define the drive information manually. You will be asked to enter the following items.

CYLS : Number of cylinders
HEAD : Number of read/write heads
PRECOMP : Write precompensation
LANDZ : Landing zone
SECTOR : Number of sectors

The Access Mode selections are as follows:

Auto
Normal (HD < 528MB)
Large (for MS-DOS only)
LBA (HD > 528MB and supports
Logical Block Addressing)

Drive A

These fields identify the types of floppy disk drive that has been installed in the computer. The available specifications are:

360KB	1.2MB	720KB	1.44MB	2.88MB
5.25 in.	5.25 in.	3.5 in.	3.5 in.	3.5 in.

Video

This field selects the type of video display card installed in your system.

You can choose the following video display cards:

- | | |
|---------|---|
| EGA/VGA | For EGA, VGA, SEGA, SVGA or PGA monitor adapters. (default) |
| CGA 40 | Power up in 40 column mode. |
| CGA 80 | Power up in 80 column mode. |
| MONO | For Hercules or MDA adapters. |

Halt On

This field determines whether or not the system will halt if an error is detected during power up.

- | | |
|-------------------|---|
| No errors | The system boot will not be halted for any error that may be detected. |
| All errors | Whenever the BIOS detects a non-fatal error, the system will stop and you will be prompted. |
| All, But Keyboard | The system boot will not be halted for a keyboard error; it will stop for all other errors |
| All, But Diskette | The system boot will not be halted for a disk error; it will stop for all other errors. |
| All, But Disk/Key | The system boot will not be halted for a keyboard or disk error; it will stop for all others. |

Advanced BIOS Features

This section allows you to configure and improve your system and allows you to set up some system features according to your preference.

Phoenix - Award Workstation BIOS CMOS Setup Utility
Advanced BIOS Features

		ITEM HELP
CPU Feature	Press Enter	
Hard Disk Booty Priority	Press Enter	Menu Level
Virus Warning	Disabled	
CPU L1 & L2 Cache	Enabled	
CPU L2 Cache ECC Checking	Enabled	
Quick Power On Self Test	Enabled	
First Boot Device	Floppy	
Second Boot Device	Hard Disk	
Third Boot Device	CDROM	
Boot Other Device	Enabled	
Swap Floppy Drive	Disabled	
Boot Up Floppy Seek	Enabled	
Boot Up Numlock Status	On	
Typematic Rate Setting	Disabled	
Typematic Rate (chars/Sec)	6	
Typematic Delay (Msec)	250	
Security Option	Setup	
APIC Mode	Enabled	
MPS Version Control for OS	1.4	
OS Select For DRAM>64MB	Non-OS2	
Video BIOS Shadow	Enabled	
Small Logo (EPA) Show	Disabled	

CPU Feature

This item allows you to set the “Delay Prior to Thermal” and “Thermal Management” where the default settings are “16 Min” and “Thermal Monitor 1

Hard Disk Booty Priority

This item allows you to arrange the priority of the devices where the system boots from.

Virus Warning

This item protects the boot sector and partition table of your hard disk against accidental modifications. If an attempt is made, the BIOS will halt the system and display a warning message. If this occurs, you can either allow the operation to continue or run an anti-virus program to locate and remove the problem.

CPU L1/L2 Cache

Cache memory is additional memory that is much faster than conventional DRAM (system memory). CPUs from 486-type on up contain internal cache memory, and most, but not all, modern PCs have additional (external) cache memory. When the CPU requests data, the system transfers the requested data from the main DRAM into cache memory, for even faster access by the CPU.

CPU L2 Cache ECC Checking

When enabled, it allows ECC checking of the CPU L2 cache. Enabling this feature is recommended because it will detect and correct single-bit errors in data stored in the L2 cache. It will also detect double-bit errors but not correct them.

Quick Power On Self Test

When enabled, this field speeds up the Power On Self Test (POST) after the system is turned on. If it is set to *Enabled*, BIOS will skip some items.

First/Second/Third Boot Device

These fields determine the drive that the system searches first for an operating system. The options available include *Floppy*, *LS/ZIP*, *HDD-0*, *SCSI*, *CDROM*, *HDD-1*, *HDD-2*, *HDD-3*, *LAN* and *Disable*.

Boot Other Device

These fields allow the system to search for an operating system from other devices other than the ones selected in the First/Second/Third Boot Device.

Swap Floppy Drive

This item allows you to determine whether or not to enable Swap Floppy Drive. When enabled, the BIOS swaps floppy drive assignments so that Drive A becomes Drive B, and Drive B becomes Drive A. By default, this field is set to *Disabled*.

Boot Up Floppy Seek

This feature controls whether the BIOS checks for a floppy drive while booting up. If it cannot detect one (either due to improper configuration or its absence), it will flash an error message.

Boot Up NumLock Status

This allows you to activate the NumLock function after you power up the system.

Typematic Rate Setting

When disabled, continually holding down a key on your keyboard will generate only one instance. When enabled, you can set the two typematic controls listed next. By default, this field is set to *Disabled*.

Typematic Rate (Chars/Sec)

When the typematic rate is enabled, the system registers repeated keystrokes speeds. Settings are from 6 to 30 characters per second.

Typematic Delay (Msec)

When the typematic rate is enabled, this item allows you to set the time interval for displaying the first and second characters.

Security Option

This field allows you to limit access to the System and Setup. When you select *System*, the system prompts for the User Password every time you boot up. When you select *Setup*, the system always boots up and prompts for the Supervisor Password only when Setup utility is called up.

MPS Version Control for OS

This option is specifies the MPS (Multiprocessor Specification) version for your operating system. MPS version 1.4 added extended configuration tables to improve support for multiple PCI bus configurations and improve future expandability. The default setting is *1.4*.

OS Select for DRAM > 64MB

This option allows the system to access greater than 64MB of DRAM memory when used with OS/2 that depends on certain BIOS calls to access memory. The default setting is *Non-OS/2*.

Video BIOS Shadow

This item allows you to change the Video BIOS location from ROM to RAM. Video Shadow will increase the video speed.

Small Logo (EPA) Show

This field enables the showing of the EPA logo located at the upper right of the screen during boot up.

Advanced Chipset Features

This Setup menu controls the configuration of the chipset.

Phoenix - AwardBIOS CMOS Setup Utility
Advanced Chipset Features

DRAM Clock / Drive Control	Press Enter	ITEM HELP
AGP & P2P Bridge Control	Press Enter	Menu Level
CPU & PCI Bus Control	Press Enter	
Memory Hole	Disabled	
System BIOS Cacheable	Enabled	
Video RAM Cacheable	Disabled	
Init Display First	PCI Slot	

Phoenix - AwardBIOS CMOS Setup Utility
DRAM Clock/Driver Control

Current FSB Frequency		ITEM HELP
Current DRAM Frequency		Menu Level
DRAM Clock	By SPD	
DRAM Timing	Auto By SPD	
DRAM CAS Latency	2.5/4	
Bank Interleave	Disabled	
Precharge to Active (Trp)	4T	
Active to Precharge (Tras)	7T	
Active to CMD(Trcd)	4T	
REF to ACT/REF to REF(Trfc)	21T	
ACT(0) to ACT(1) TRRD	3T	
Read to Precharge (Trtp)	2T	
Write to Read CMD (Twtr)	1T/2T	
Write Recovery Time (Twr)	4T	
DRAM Command Rate	2T Command	
RDSAIT Mode	Auto	
RDSAIT Selection	03	

Phoenix - AwardBIOS CMOS Setup Utility
AGP & P2P Bridge Control

AGP Aperture Size	128M	ITEM HELP
AGP 3.0 Mode	8X	Menu Level
AGP Driving Control	Auto	
AGP Driving Value	DA	
AGP Fast Write	Disabled	
AGP Master 1 WS Write	Enabled	
AGP Master 1 WS Read	Enabled	
AGP 3.0 Calibration cycle	Disabled	
VGA Share Memory Size	64M	
Direct Frame Buffer	Enabled	
Select Display Device	CRT+LVDS	
Panel Type	1024 x 768 18bit SC	
Outpost Port	DIO	
Dithering	Disabled	
TV Layout	Default	
TV Type	NTSC	
TV Connector	CVBS	

Phoenix - AwardBIOS CMOS Setup Utility
CPU & PCI Bus Control

PCI Master 0 WS Write	Enabled	ITEM HELP
PCI Delay Transaction	Enabled	Menu Level
Vlink mode selection	By Auto	Menu Level
Vlink 8x Support	Enabled	
DRDY Timing	Default	

DRAM Clock / Drive Control

This field provides settings related to DRAM. The fields are listed below.

Current FSB Frequency

The default setting of the FSB Frequency is 100MHz.

Current DRAM Frequency

The default setting of the DRAM Frequency is 266MHz.

DRAM Clock

The default setting of the DRAM clock is SPD.

DRAM Timing

This option refers to the method by which the DRAM timing is selected. The default is Auto by SPD.

DRAM CAS Latency

This is the period between when the chipset requests data from memory and when the memory is ready to send the data across the bus.

Bank Interleave

This decides how multiple memory modules communicate. It will only make a difference if you have more than one memory module.

Precharge to Active(Trp)

The amount of time from a bank precharge request to when it can be activated.

Active to Precharge(Tras)

The Active to Precharge timing controls the length of the delay between the activation and precharge commands – the length of time after activation can the access cycle be started again.

Active to CMD(Tred)

This is the time between a row access request and a column access request.

REF to ACT/REF to REF(Trfc)

The default setting is 21T.

ACT(0) to ACT(1) (TRRD)

The default time setting is 4T.

DRAM Command Rate

The time to wait after a chip select before activate and read can be started.

Read to Precharge (Trtp)

The default time setting is 2T.

Write to Read CMD (Twtr)

The default time setting is 1T/2T.

Write Recovery Time

The default time setting is 4T.

DRAM Command Rate

The time to wait after a chip select before activate and read can be started.

RDSAIT Mode

The default time setting is Auto.

RDSAIT Selection

The default time setting is 03.

AGP & P2P Bridge Control

The fields related to AGP & P2P Bridge Control are listed below.

AGP Aperture Size

The field sets aperture size of the graphics. The aperture is a portion of the PCI memory address range dedicated for graphics memory address space. Host cycles that hit the aperture range are forwarded to the AGP without any translation. The default setting is 64M.

AGP 3.0 Mode

The default setting is 8X.

AGP Driving Value

This decides how multiple memory modules communicate. It will only make a difference if you have more than one memory module.

AGP Fast Write

This accelerates memory write transactions from the chipset to the AGP device.

AGP Master 1 WS Write

When enabled, this changes the default from a 2ws to a 1ws which will increase AGP Writing.

AGP Master 1 WS Read

By default, the AGP busmastering device waits for at least 2 wait states before it starts a write transaction. When enable, this option sets the delay to 1 wait state.

AGP 3.0 Calibration cycle

By default, this field is disabled.

VGA Share memory Size

By default, this field is set to 64M.

Direct Frame Buffer

By default, this field is set to Enabled.

Select Display Device

By default, this field is set to CRT+LVDS.

Panel Type

By default, this field is set to 1024x768 18Bit SC02.

Outport Port

By default, this field is set to DIO.

Dithering

By default, this field is set to Disabled.

TV H/W Layout

By default, this field is set to Default.

TV Type

By default, this field is set to NTSC.

TV Output Connector

The field allows you to choose the TV output connector to be used.

CPU & PCI Bus Control

The fields related to CPU & PCI Bus Control are listed below.

PCI Master 0 WS Write

This determines whether the chipset inserts a delay before any writes from the PCI bus.

PCI Delay Transaction

This is used to meet the latency of PCI cycles to and from the ISA bus.

Vlink mode selection

The default is set to By Auto.

Vlink 8X Support

By default, this field is enabled.

DRDY_Timing

By default, this field is set to Default.

Integrated Peripherals

This section sets configurations for your hard disk and other integrated peripherals.

Phoenix - Award Workstation BIOS CMOS Setup Utility
Integrated Peripherals

VIA OnChip IDE Device	Press Enter	ITEM HELP
VIA OnChip PCI Device	Press Enter	
SuperIO Device	Press Enter	Menu Level
2nd SuperIO Device	Press Enter	
Onboard Serial Port 3	3E8h	
Serial Port 3 Use IRQ	IRQ11	
Onboard Serial Port 4	2E8h	
Serial Port 4 Use IRQ	IRQ10	

VIA OnChip IDE Device

Upon pressing Enter on this field, another window appears. Below are the fields shown with their respective default settings:

- OnChip SATA – Enabled
- SATA Mode – IDE
- OnChip IDE Channel0 – Enabled
- OnChip IDE Channel1 – Enabled
- IDE Prefetch Mode – Enabled
- Primary Master PIO – Auto
- Primary Slave PIO – Auto
- Secondary Master PIO – Auto
- Secondary Slave PIO – Auto
- Primary Master UDMA – Auto
- Primary Slave UDMA – Auto
- Secondary Master UDMA – Auto
- Secondary Slave UDMA – Auto
- IDE HDD Block Mode – Enabled

VIA OnChip PCI Device

Upon pressing Enter on this field, another window appears. Below are the fields shown with their respective default settings:

- VIA-3058 AC97 Audio – Auto
- VIA-3043 OnChip LAN – Enabled
- Onboard LAN Boot ROM – Disabled
- OnChip USB Controller – Enabled
- OnChip EHCI Controller – Enabled
- USB Emulation – OFF
- USB Keyboard Support – Disabled
- USB Mouse Support – Disabled

SuperIO Device

Upon pressing Enter on this field, another window appears. Below are the fields shown with their respective default settings:

- Onboard FDC Controller – Enabled
- Onboard Serial Port 1 – 3F8/IRQ4
- Onboard Serial Port 2 – 2F8/IRQ3
- UART Mode Select – Normal

2nd Super I/O Device

Upon pressing Enter on this field, another window appears. Below are the fields shown with their respective default settings:

- Onboard Serial Port 3 – 3E8h
- Serial Port 3 Use IRQ – IRQ11
- Onboard Serial Port 4 – 2E8h
- Serial Port 4 Use IRQ – IRQ10

Power Management Setup

The Power Management Setup allows you to save energy of your system effectively.

Phoenix - Award Workstation BIOS CMOS Setup Utility
Power Management Setup

		ITEM HELP
ACPI Function	Enabled	
ACPI Suspend Type	S1 (POS)	Menu Level
Power Management Option	User Define	
HDD Power Down	Disabled	
Suspend Mode	Disabled	
Video Off Option	Suspend -> Off	
Video Off Method	V/H SYNC+Blank	
Modem Use IRQ	3	
Soft-Off by PWR-BTTN	Instant-Off	
Run VGA BIOS if S3 Resume	Auto	
Ac Loss Auto Restart	Off	
IRQ/Event Activity Detect	Press Enter	

ACPI Function

Enable this function to support ACPI (Advance Configuration and Power Interface).

Power Management Option

This field allows you to select the type of power saving management modes. There are four selections for Power Management.

Min. Power Saving	Minimum power management
Max. Power Saving	Maximum power management.
User Define	Each of the ranges is from 1 min. to 1hr. Except for HDD Power Down which ranges from 1 min. to 15 min.

HDD Power Down

When enabled, and after the set time of system inactivity, the hard disk drive will be powered down while all other devices remain active.

Suspend Mode

BIOS will turn the HDD's motor off when system is in SUSPEND mode. By default, this field is disabled.

Video Off Option

This field sets the video off option. By default, video goes into suspend state and then Off.

Video Off Method

This field defines the Video Off features. There are three options.

V/H SYNC + Blank	Default setting, blank the screen and turn off vertical and horizontal scanning.
DPMS	Allows BIOS to control the video display.
Blank Screen	Writes blanks to the video buffer.

Modem Use IRQ

The default setting of this field is 3.

Soft-Off by PWRBTN

This field defines the power-off mode when using an ATX power supply. The *Instant Off* mode allows powering off immediately upon pressing the power button. In the *Delay 4 Sec* mode, the system powers off when the power button is pressed for more than four seconds or enters the suspend mode when pressed for less than 4 seconds.

Run VGABIOS if S3 Rsume

The default setting is Auto.
AC power loss.

AC Loss Auto Restart

This field sets the auto restarting function of the system when there is AC power loss.

IRQ/Event Activity Detect

The items under this field are I/O events that can prevent the system from entering a power saving mode or can awaken the system from such a mode. When an I/O device wants to gain the attention of the operating system, it signals this by causing an IRQ to occur. When the operating system is ready to respond to the request, it interrupts itself and performs the service.

Phoenix - AwardBIOS CMOS Setup Utility
IRQ/Event Activity Detect

USB Resume from S3	Disabled	ITEM HELP
VGA	OFF	Menu Level
LPT & COM	LPT / COM	
HDD & FDD	ON	
PCI Master	OFF	
PowerOn by PCI Card	Disabled	
Modem Ring Resume	Disabled	
RTC Alarm Resume	Disabled	
IRQs Activity Monitoring	Press Enter	

IRQ Activity Monitoring

When you press Enter on this field, the following window appears.

Phoenix - AwardBIOS CMOS Setup Utility
IRQs Activity Monitoring

Primary INTR	ON	ITEM HELP
IRQ3 (COM2)	Disabled	Menu Level
IRQ4 (COM1)	Enabled	
IRQ5 (LPT 2)	Enabled	
IRQ6 (Floppy Disk)	Enabled	
IRQ7 (LPT 1)	Enabled	
IRQ8 (RTC Alarm)	Disabled	
IRQ9 (IRQ2 Redir)	Disabled	
IRQ10 (Rerved)	Disabled	
IRQ11 (Reserved)	Disabled	
IRQ12 (PS/2 Mouse)	Enabled	
IRQ13 (Coprocessor)	Enabled	
IRQ14 (Hard Disk)	Enabled	
IRQ15 (Reserved)	Disabled	

PNP/PCI Configurations

This option configures the PCI bus system. All PCI bus systems on the system use INT#, thus all installed PCI cards must be set to this value.

Phoenix - Award Workstation BIOS CMOS Setup Utility
PnP/PCI Configurations

PNP OS Installed	No	ITEM HELP Menu Level
Reset Configuration Data	Disabled	
Resources Controlled By IRQ Resources	Auto (ESCD) Press Enter	Default is Disabled. Select Enabled to reset Extended System Configuration Data (ESCD) when you exit Setup if you have installed a new add-on and the system reconfiguration has caused such a serious conflict that the OS cannot boot
PCI/VGA Palette Snoop	Disabled	
Assign IRQ for VGA	Enabled	
Assign IRQ for USB	Enabled	

PNP OS Installed

Enable the PNP OS Install option if it is supported by the operating system installed. The default value is *No*.

Reset Configuration Data

This field allows you to determine whether to reset the configuration data or not. The default value is *Disabled*.

Resources Controlled by

This PnP BIOS can configure all of the boot and compatible devices automatically with the use of a use a PnP operating system such as Windows 95.

PCI/VGA Palette Snoop

Some non-standard VGA display cards may not show colors properly. This field allows you to set whether or not MPEG ISA/VESA VGA cards can work with PCI/VGA. When this field is enabled, a PCI/VGA can work with an MPEG ISA/VESA VGA card. When this field is disabled, a PCI/VGA cannot work with an MPEG ISA/VESA card.

Assign IRQ for VGA

This field enables the assigning of an IRQ for VGA.

Assign IRQ for USB

This field enables the assigning of an IRQ for USB.

PC Health Status

Phoenix - Award Workstation BIOS CMOS Setup Utility
PC Health Status

		ITEM HELP
Thermal Duty Cycle	Disabled	
CPU Warning Temperature	Disabled	
System Temp.	39°C/102°F	
CPU Temp.	32°C/89°F	
CPU FAN Speed	0 RPM	
System FAN Speed	0 RPM	
Vcore	1.63V	
3.3V	3.37V	
+5V	5.05V	
+12V	12.09V	
-12V	-12.03V	
-5V	- 4.79V	
VBAT(V)	3.21V	
5VSB(V)	5.05V	
Shutdown Temperature	Disabled	

Thermal Duty Cycle

By default, this field is disabled.

CPU Warning Temperature

This field allows the user to set the temperature so that when the temperature is reached, the system sounds a warning. This function can help prevent damage to the system that is caused by overheating.

Temperatures/Fan Speeds/Voltages

These fields are the parameters of the hardware monitoring function feature of the motherboard. The values are read-only values as monitored by the system and show the PC health status.

Shutdown Temperature

This field allows the user to set the temperature by which the system automatically shuts down once the threshold temperature is reached. This function can help prevent damage to the system that is caused by overheating.

Frequency/Voltage Control

This section shows the user how to configure the processor frequency.

Phoenix - Award Workstation BIOS CMOS Setup Utility
Frequency/Voltage Control

Auto Detect PCI/DIMM Clk	Disabled	ITEM HELP
Spread Spectrum	Disabled	Menu Level
CPU Host/AGP/PCI Clock	Default	

Auto Detect PCI/DIMM Clk

This field enables or disables the auto detection of the PCI/DIMM clock.

Spread Spectrum

This field sets the value of the spread spectrum. The default setting is *Disabled*. This field is for CE testing use only.

CPU Host/AGP/PCI Clock

This field is set to Default.

Load Fail-Safe Defaults

This option allows you to load the troubleshooting default values permanently stored in the BIOS ROM. These default settings are non-optimal and disable all high-performance features.

Load Optimized Defaults

This option allows you to load the default values to your system configuration. These default settings are optimal and enable all high performance features.

Set Supervisor/User Password

These two options set the system password. Supervisor Password sets a password that will be used to protect the system and Setup utility. User Password sets a password that will be used exclusively on the system. To specify a password, highlight the type you want and press <Enter>. The Enter Password: message prompts on the screen. Type the password, up to eight characters in length, and press <Enter>. The system confirms your password by asking you to type it again. After setting a password, the screen automatically returns to the main screen.

To disable a password, just press the <Enter> key when you are prompted to enter the password. A message will confirm the password to be disabled. Once the password is disabled, the system will boot and you can enter Setup freely.

Save & Exit Setup

This option allows you to determine whether or not to accept the modifications. If you type “Y”, you will quit the setup utility and save all changes into the CMOS memory. If you type “N”, you will return to Setup utility.

Exit Without Saving

Select this option to exit the Setup utility without saving the changes you have made in this session. Typing “Y” will quit the Setup utility without saving the modifications. Typing “N” will return you to Setup utility.

Drivers Installation

This section describes the installation procedures for software and drivers under the Windows 98, Windows NT 4.0 and Windows 2000. The software and drivers are included with the motherboard. If you find the items missing, please contact the vendor where you made the purchase. The contents of this section include the following:

VIA CN700 4 in 1 Driver Installation	52
Realtek AC'97 Codec Audio Driver Installation	54
VIA VT8237 LAN Driver Installation.....	55
Realtek Gigabit LAN Driver Installation.....	55
VIA RAID Driver Installation	56
VIA CN700 VGA Driver Installation.....	58

IMPORTANT NOTE:

After installing your Windows operating system (Windows 98/98SE/ME/2000/XP), you must install first the Chipset Software Installation Utility before proceeding with the drivers installation.

VIA CN700 4 in 1 Driver Installation

Follow the steps below to install the chipset drivers of the VIA CN700 chipset under Windows 98/98SE/ME/2000/XP.

1. Insert the CD that comes with the motherboard and the screen below would appear. Click 4 IN 1 Drivers. The VIA HyperionPro Setup Wizard welcome screen will appear. Click Next to continue. When the license agreement window appears, click "I Agree", then click Next to continue.

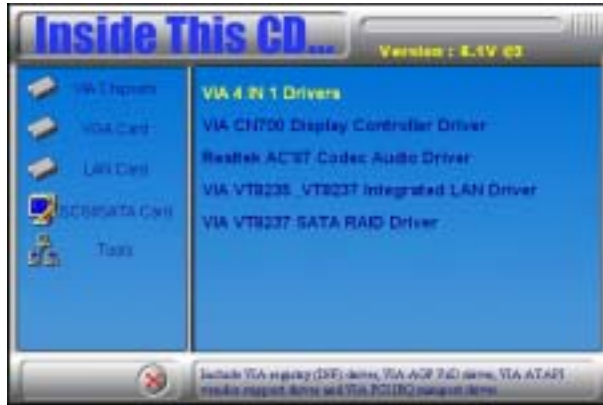

2. In the following window, click all the components to be installed, and click Next to continue.

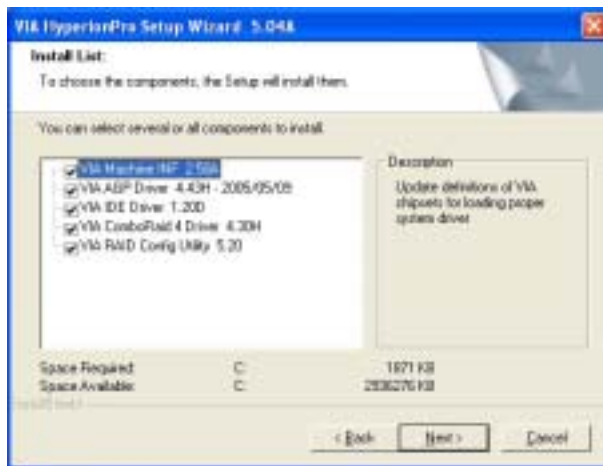

3. You are now asked to review setting before installing the components, click Next to continue.

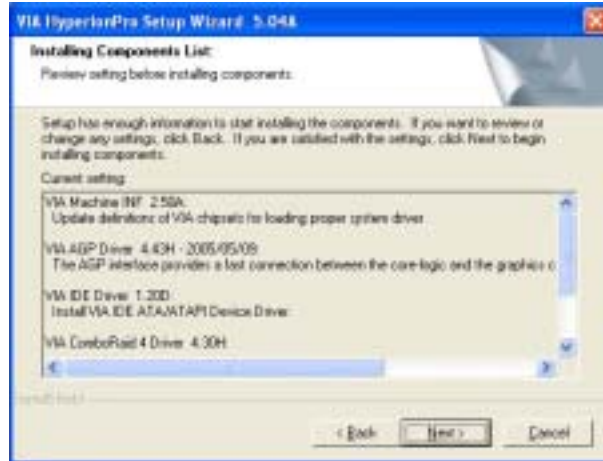

4. The following window shows you the installing status with the result. Click Next. The installation process is now complete. Restart the computer as prompted for changes to take effect

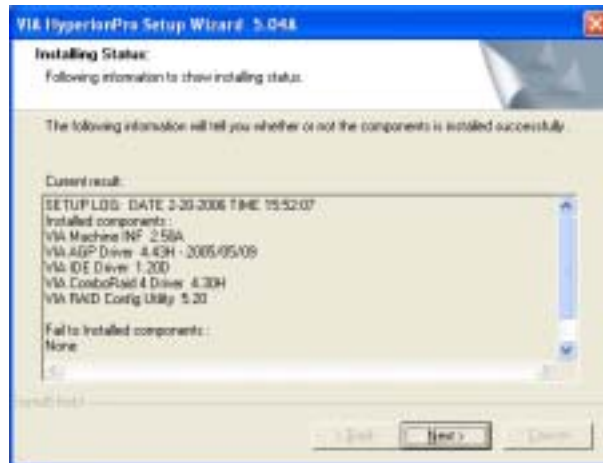

Realtek AC'97 Codec Audio Driver Installation

Follow the steps below to install the Realtek AC'97 Codec Audio Driver under Windows 98/98SE/ME/2000/XP.

1. Insert the CD that comes with the motherboard and the screen below would appear. Click Realtek AC'97 Codec Audio Driver and the Audio Setup welcome screen would appear. Click Next.



2. In the following screen you will be informed that the Realtek 'AC97 audio controller has not passed Windows logo testing. Click "Continue Anyway" to proceed with the installation. After the installation is complete, click Finish to restart the computer.

VIA VT8237 LAN Driver Installation

1. Insert the CD that comes with the motherboard and the screen below would appear. Click VIA VT8235 VT8237 Integrated LAN Driver and the drivers will automatically be installed.

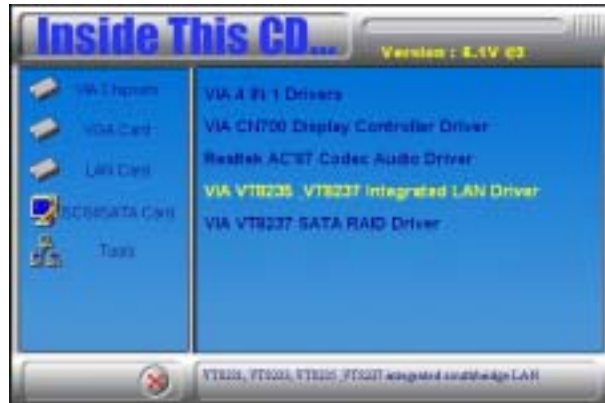

Realtek Gigabit LAN Driver Installation

1. Insert the CD that comes with the motherboard and the screen below would appear. Click on LAN Card. On the next screen, click on Realtek Network Interface Controller Drivers. When the welcome screen appears, click Next to continue. After the installation, you will be prompted to restart the computer. Click Finish.



VIA RAID Driver Installation

1. Insert the CD that comes with the motherboard and the screen below would appear. Click VIA VT8237 SATA RAID Driver. The VIA welcome screen will appear. Click Next to continue. When the license agreement window appears, click “I Agree”, then click Next to continue.

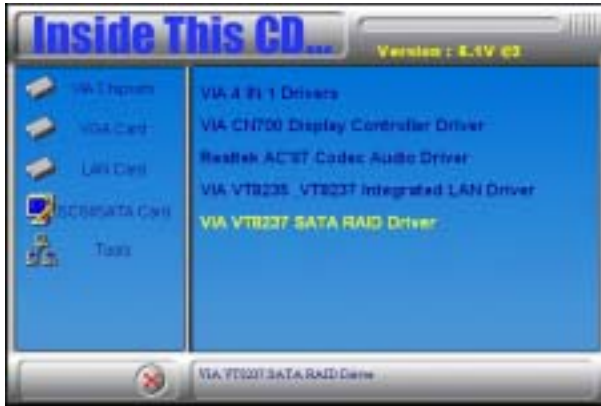

2. The installation list window now appears. Click the SATA RAID controller driver checkbox and click Next.



4. The following windows show you components list and the installing status. Click Next. When installation process is complete, restart the computer as prompted for changes to take effect

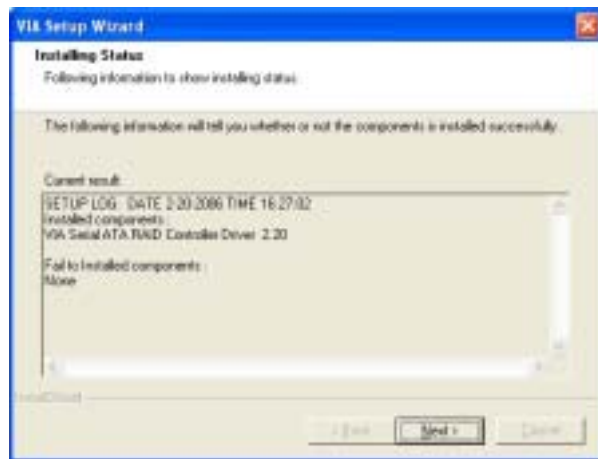
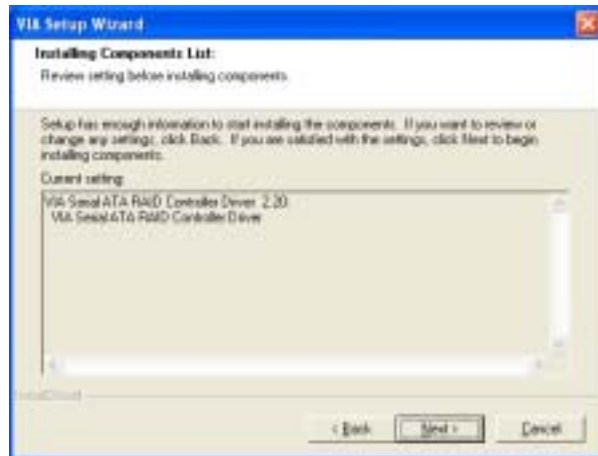

VIA CN700 VGA Driver Installation

Follow the steps below to install the VIA CN700 VGA Driver under Windows 98/98SE/ME/2000/XP.

1. Insert the CD that comes with the motherboard and the screen below would appear. Click on VIA CN700 Display Controller Driver to start the installation.

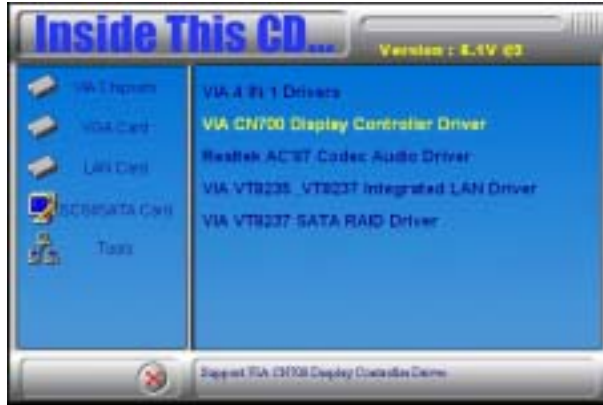

2. Click Finish to complete the installation.

Appendix

A. I/O Port Address Map

Each peripheral device in the system is assigned a set of I/O port addresses that also becomes the identity of the device. The following table lists the I/O port addresses used.

Address	Device Description
000h - 01Fh	DMA Controller #1
020h - 03Fh	Interrupt Controller #1
040h - 05Fh	Timer
060h - 06Fh	Keyboard Controller
070h - 07Fh	Real Time Clock, NMI
080h - 09Fh	DMA Page Register
0A0h - 0BFh	Interrupt Controller #2
0C0h - 0DFh	DMA Controller #2
0F0h	Clear Math Coprocessor Busy Signal
0F1h	Reset Math Coprocessor
1F0h - 1F7h	IDE Interface
278 - 27F	Parallel Port #2(LPT2)
2F8h - 2FFh	Serial Port #2(COM2)
2B0 - 2DF	Graphics adapter Controller
378h - 3FFh	Parallel Port #1(LPT1)
360 - 36F	Network Ports
3B0 - 3BF	Monochrome & Printer adapter
3C0 - 3CF	EGA adapter
3D0 - 3DF	CGA adapter
3F0h - 3F7h	Floppy Disk Controller
3F8h - 3FFh	Serial Port #1(COM1)

B. Interrupt Request Lines (IRQ)

Peripheral devices use interrupt request lines to notify CPU for the service required. The following table shows the IRQ used by the devices on board.

Level	Function
IRQ0	System Timer Output
IRQ1	Keyboard
IRQ2	Interrupt Cascade
IRQ3	Serial Port #2
IRQ4	Serial Port #1
IRQ5	Reserved
IRQ6	Floppy Disk Controller
IRQ7	Parallel Port #1
IRQ8	Real Time Clock
IRQ9	Reserved
IRQ10	Reserved
IRQ11	Reserved
IRQ12	PS/2 Mouse
IRQ13	80287
IRQ14	Primary IDE
IRQ15	Secondary IDE