

# IP510

Nano ETX COM Express  
Baseboard

## USER'S MANUAL

Version 1.0

---

## Acknowledgments

Award is a registered trademark of Award Software International, Inc.

PS/2 is a trademark of International Business Machines Corporation.

Intel and Pentium M are registered trademarks of Intel Corporation.

Microsoft Windows is a registered trademark of Microsoft Corporation.

Winbond is a registered trademark of Winbond Electronics Corporation.

All other product names or trademarks are properties of their respective owners.

---

# Table of Contents

<b>Introduction .....</b>	<b>1</b>
IP510 Specifications.....	1
Board Dimensions .....	2
<b>Installations .....</b>	<b>3</b>
Installing the CPU Module.....	4
Setting the Jumpers .....	5
Connectors on IP510 .....	9

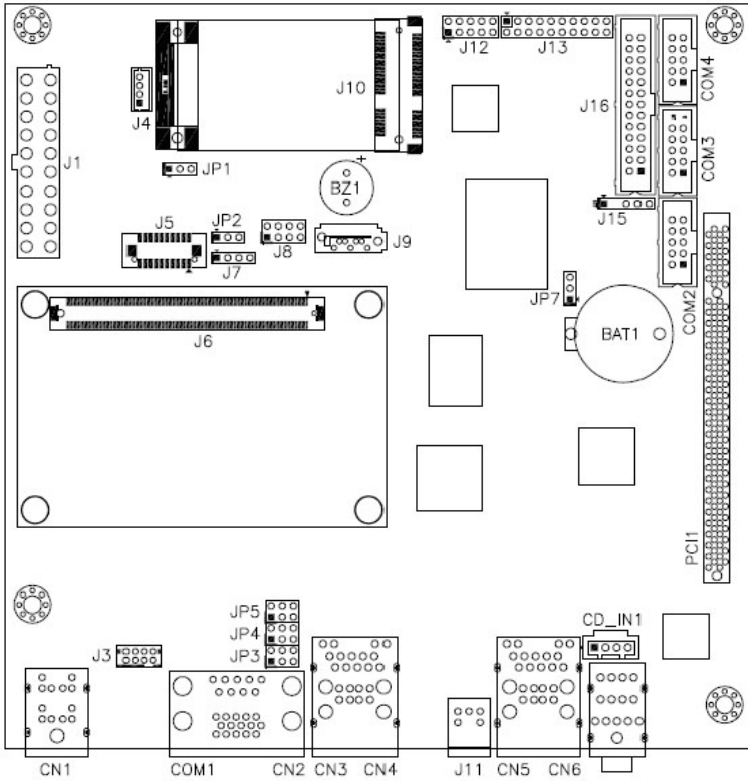

The IP510 Baseboard

# Introduction

## IP510 Specifications

<b>Product Name</b>	<b>IP510</b>
<b>Form Factor</b>	Baseboard for ET830 Nano ETX Express type I CPU module
<b>BIOS</b>	Phoenix BIOS
<b>VGA</b>	Derived from Nano ETX Express module
<b>LVDS</b>	Derived from Nano ETX Express module, supporting 24bit
<b>USB</b>	Derived from Nano ETX Express module w/ 6 x USB2.0 ports
<b>IDE Interface</b>	Derived from Nano ETX Express module
<b>PCIe to PCIe</b>	PLX PEX8505 switch for 3 x PCIe(1x)
<b>PCIe to PCI</b>	PLX PEX8112 bridge
<b>LAN</b>	Realtek 8111DL PCI Express Gigabit LAN x2
<b>SATA</b>	Derived from Nano ETX Express module x 1 port
<b>Audio</b>	Derived from ETX module w/ ALC662 5.1 CH audio (line-out, line-in & Mic.)
<b>LPC Super I/O</b>	Winbond W83627EHG + Fintek F81216 : COM1 (RS232/422/485), COM2(RS232), COM3 (RS232), COM4 (RS232) . Hardware monitor (2 thermal inputs, 1 voltage monitor inputs)
<b>PS/2 KB &amp; Mouse</b>	Derived from Nano ETX Express module
<b>Digital I/O</b>	4-in/4-out
<b>Battery for RTC/CMOS</b>	Lithium battery for RTC of Nano ETX Express module
<b>Edge Connectors</b>	PS/2 connector x1 for keyboard & mouse GbE LAN RJ-45 + dual USB stack connector x 2 DB15 x 1 for VGA DB9 x 1 for COM 1 DB25 x 1 for LPT RCA jack 3x1 for HD audio
<b>On Board Connectors / Headers</b>	DF13 x1 for LVDS 10 (5x2) pins box-header x3 for serial ports (COM2~COM4) 8 (4x2) pins header x 1 for USB5~6 SATA connector x1 2 x 4 pins header x1 for Digital I/O
<b>Expansion</b>	Mini-PCIe (1x) slot x 1 + 1 x default USB PCI slot x 1 (Thru PCI-e to PCI bridge PLX PEX8112)
<b>Power Connector</b>	ATX
<b>Operation Temperature</b>	0°C~60°C
<b>Storage Temperature</b>	-20°C~80°C
<b>Relative Humidity</b>	10% ~ 90% (non-condensing)
<b>RoHS Compliant</b>	Yes
<b>Board Size</b>	170 x 170mm

# Board Dimensions

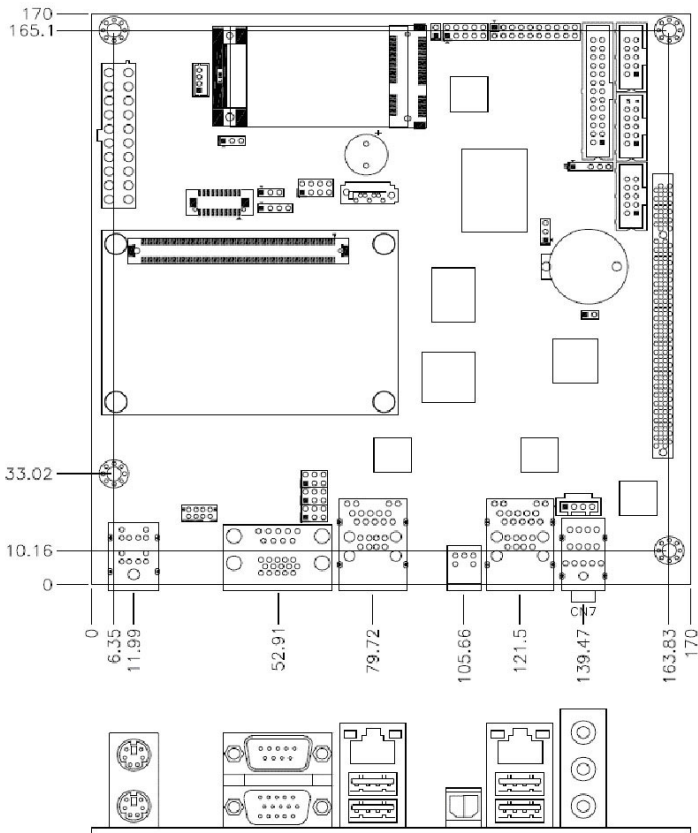

## Installations

This section provides information on how to use the jumpers and connectors on the IP510 in order to set up a workable system. The topics covered are:

Installing the CPU Module .....	4
Setting the Jumpers.....	5
Connectors on IP510 .....	9

## **Installing the CPU Module**

---

---

The IP510 board supports Nano ETX COM Express CPU module such as the ET830. Below is a picture showing how the CPU module and the heatsink should be installed on the IP510 baseboard. There are five holes on the IP510 that can be used to screw the three parts together – the heatsink, the CPU module and the baseboard.

---

## Setting the Jumpers

---

---

Jumpers are used on IP510 to select various settings and features according to your needs and applications. Contact your supplier if you have doubts about the best configuration for your needs. The following lists the connectors on IP510 and their respective functions.

Jumper Locations on IP510 .....	6
JP1: LVDS Panel Power.....	7
JP2: USB2 Host/Client Selection .....	7
JP3, JP4, JP5: RS232/422/485 (COM1) Selection .....	7
JP7: Clear CMOS Contents .....	8

Jumper Locations on IP510

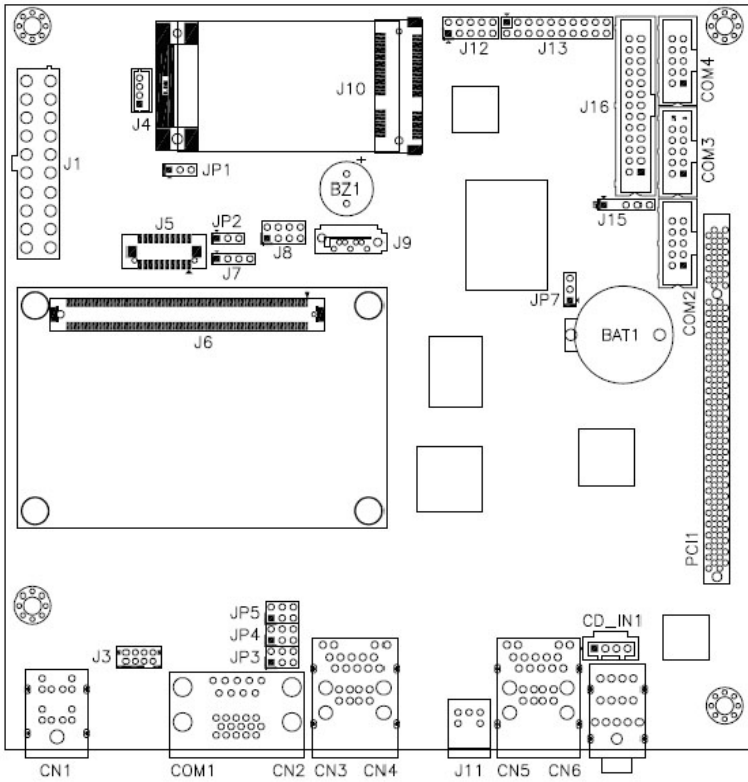

Jumpers on IP510 ..... Page



JP1: LVDS Panel Power..... 7

JP2: USB2 Host/Client Selection..... 7



JP3, JP4, JP5: RS232/422/485 (COM1) Selection ..... 7

JP7: Clear CMOS Contents ..... 8

**JP1: LVDS Panel Power**

JP1	LVDS Panel Power
	+3.3V (default)
	+5V

**JP2: USB2 Host/Client Selection**

JP2	USB2 TYPE
	Host
	Client

**JP3, JP4, JP5: RS232/422/485 (COM1) Selection**

COM2~COM4 are fixed for RS-232 use only.



COM1 is selectable for RS232, RS-422 and RS-485.

The following table describes the jumper settings for COM1 selection.

COM1 Function	RS-232	RS-422	RS-485
Jumper Setting (pin closed)	JP3: 3-5 & 4-6	JP3: 1-3 & 2-4	JP3: 1-3 & 2-4
	JP4: 3-5 & 4-6	JP4: 1-3 & 2-4	JP4: 1-3 & 2-4
	JP5: 1-2	JP5: 3-4	JP5: 5-6

**JP7: Clear CMOS Contents**

Use JP7 to clear the CMOS contents. *Note that the ATX-power connector should be disconnected from the board before clearing CMOS.*

JP7	Setting	Function
 1 2 3	Pin 1-2 Short/Closed	Normal
 1 2 3	Pin 2-3 Short/Closed	Clear CMOS

---

## Connectors on IP510

---

The connectors on IP510 allows you to connect external devices such as keyboard, floppy disk drives, hard disk drives, printers, etc. The following table lists the connectors on IP510 and their respective functions.

Connector Locations on IP510 .....	10
CN1: PS/2 Keyboard and PS/2 Mouse Connectors.....	11
CN2: COM2 and VGA Connector .....	11
CN3: 10/100 RJ-45 and USB4/5 Ports.....	11
CN6: Gigabit RJ-45 and USB0/1 Ports .....	11
CN7: Audio Connector.....	11
COM2~COM4: COM2~COM4 Serial Ports.....	12
J1: ATX Power Supply Connector .....	12
J3: TV-OUT (Y,Pr,Pb) Connector out (DF11).....	12
J4 : Panel Inverter Power Connector .....	13
J5: LVDS Connector .....	13
J6: Nano ETX COM Express Connector.....	13
J7: USB2 Port Pin Header .....	13
J8: USB6, USB7 Ports Pin Header.....	14
J9: SATA-IDE Connector .....	14
J10: Mini PCI- E(x1) Connector .....	14
J11: SPDIF Out Connector.....	14
J12: Digital I/O.....	14
J13: System Function Connector.....	14
J15: IrDA Connector .....	16
J16: Parallel Port Connector.....	16
CD_IN1: CD-In Connector .....	16
PCI1: PCI Slot.....	16

Connector Locations on IP510

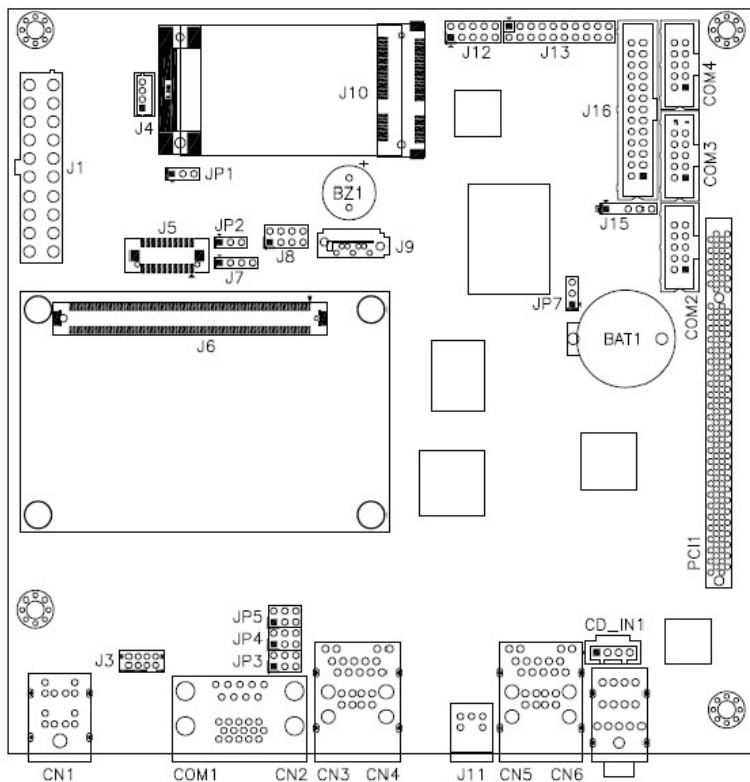

**CN1: PS/2 Keyboard and PS/2 Mouse Connectors**

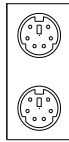

PS/2 Mouse

PS/2 Keyboard

Signal Name	Keyboard	Mouse	Signal Name
Keyboard data	1	1	Mouse data
N.C.	2	2	N.C.
GND	3	3	GND
5V	4	4	5V
Keyboard clock	5	5	Mouse clock
N.C.	6	6	N.C.

**CN2: COM2 and VGA Connector**

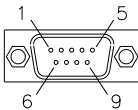

**COM2**

Signal Name	Pin #	Pin #	Signal Name
DCD	1	6	DSR
RXD	2	7	RTS
TXD	3	8	CTS
DTR	4	9	RI
GND	5	10	Not Used

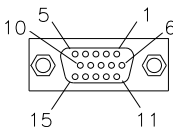

**VGA**

Signal Name	Pin #	Pin #	Signal Name
Red	1	2	Green
Blue	3	4	N.C.
GND	5	6	GND
GND	7	8	GND
N.C.	9	10	GND
N.C.	11	12	N.C.
HSYNC	13	14	VSYNC
NC	15		

**CN3: 10/100 RJ-45 and USB4/5 Ports**

**CN6: Gigabit RJ-45 and USB0/1 Ports**

**CN7: Audio Connector**

### COM2~COM4: COM2~COM4 Serial Ports

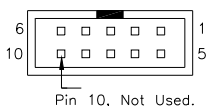

COM2

Signal Name	Pin #	Pin #	Signal Name
DCD, Data carrier detect	1	6	DSR, Data set ready
RXD, Receive data	2	7	RTS, Request to send
TXD, Transmit data	3	8	CTS, Clear to send
DTR, Data terminal ready	4	9	RI, Ring indicator
GND, ground	5	10	Not Used

### J1: ATX Power Supply Connector

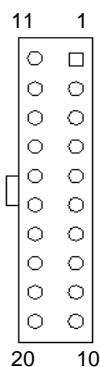

Signal Name	Pin #	Pin #	Signal Name
3.3V	11	1	3.3V
-12V	12	2	3.3V
Ground	13	3	Ground
PS-ON	14	4	+5V
Ground	15	5	Ground
Ground	16	6	+5V
Ground	17	7	Ground
-5V	18	8	Power good
+5V	19	9	5VSB
+5V	20	10	+12V

### J3: TV-OUT (Y,Pr,Pb) Connector out (DF11)



Signal Name	Pin	Pin	Signal Name
NC	1	2	NC
Y	3	4	Ground
C/Pr	5	6	Ground
CVBS/Pb	7	8	Ground

**J4 : Panel Inverter Power Connector**

Pin #	Signal Name
1	+12V
2	Backlight Enable
3	ADJ
4	Ground

**J5: LVDS Connector**

The LVDS connector supports single-channel 18-bit or 24-bit displays.

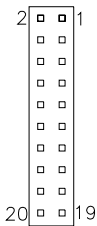

Signal Name	Pin #	Pin #	Signal Name
TX0-	2	1	TX0+
Ground	4	3	Ground
TX1-	6	5	TX1+
5V/3.3V	8	7	Ground
TX3-	10	9	TX3+
TX2-	12	11	TX2+
Ground	14	13	Ground
TXC-	16	15	TXC+
5V/3.3V	18	17	ENABKL
DDC_DATA	20	19	DDC_CLK

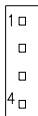
**J6: Nano ETX COM Express Connector****J7: USB2 Port Pin Header**

Pin #	Signal Name
1	Vcc
2	D-
3	D+
4	Ground

**J8: USB6, USB7 Ports Pin Header**



Signal Name	Pin	Pin	Signal Name
Vcc	1	5	Ground
D-	2	6	D+
D+	3	7	D-
Ground	4	8	Vcc

**J9: SATA-IDE Connector**

**J10: Mini PCI- E(x1) Connector**

**J11: SPDIF Out Connector**

**J12: Digital I/O**

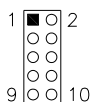

Signal Name	Pin	Pin	Signal Name
GND	1	2	VCC
OUT3	3	4	OUT1
OUT2	5	6	OUT0
IN3	7	8	IN1
IN2	9	10	IN0

**J13: System Function Connector**

J13 provides connectors for system indicators that provide light indication of the computer activities and switches to change the computer status. J3 is a 20-pin header that provides interfaces for the following functions.

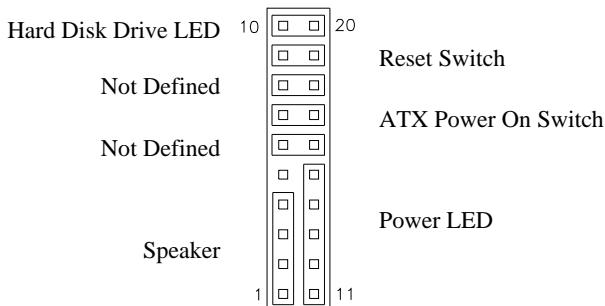

**Speaker: Pins 1 - 4**

This connector provides an interface to a speaker for audio tone generation. An 8-ohm speaker is recommended.

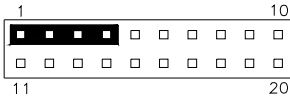

Pin #	Signal Name
1	Speaker out
2	No connect
3	Ground
4	+5V

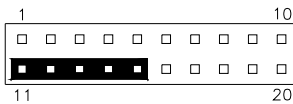
**Power LED: Pins 11 - 15**

Pin #	Signal Name
11	Power LED
12	No connect
13	Ground
14	No connect
15	Ground

**ATX Power ON Switch: Pins 7 and 17**

This 2-pin connector is an “ATX Power Supply On/Off Switch” on the system that connects to the power switch on the case. When pressed, the power switch will force the system to power on. When pressed again, it will force the system to power off.

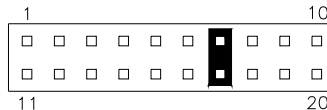
**Reset Switch: Pins 9 and 19**

The reset switch allows the user to reset the system without turning the main power switch off and then on again. Orientation is not required when making a connection to this header.

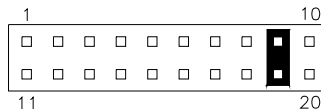

**Hard Disk Drive LED Connector: Pins 10 and 20**

This connector connects to the hard drive activity LED on control panel. This LED will flash when the HDD is being accessed.

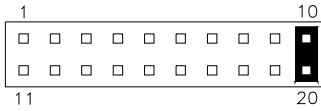

Pin #	Signal Name
10	HDD Active
20	5V

**J15: IrDA Connector**

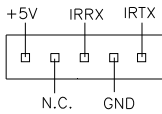

Pin #	Signal Name
1	+5V
2	No connect
3	Ir RX
4	Ground
5	Ir TX

**J16: Parallel Port Connector**

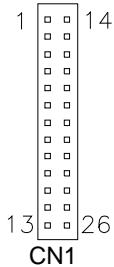

Signal Name	Pin #	Pin #	Signal Name
Line printer strobe	1	14	AutoFeed
PD0, parallel data 0	2	15	Error
PD1, parallel data 1	3	16	Initialize
PD2, parallel data 2	4	17	Select
PD3, parallel data 3	5	18	Ground
PD4, parallel data 4	6	19	Ground
PD5, parallel data 5	7	20	Ground
PD6, parallel data 6	8	21	Ground
PD7, parallel data 7	9	22	Ground
ACK, acknowledge	10	23	Ground
Busy	11	24	Ground
Paper empty	12	25	Ground
Select	13	N/A	N/A

**CD\_IN1: CD-In Connector**



Pin #	Signal Name
1	CD L
2	Ground
3	Ground
4	CD R

**PCI1: PCI Slot**